

**A**

# LEDA

**S349-REG2W2S**

A	B	C	D	A	B	C	D		
1	S349-0007	830	275	2/3	8	S349-3008	866	378	2/3
2	S349-0008	763	413	3/3	9	S349-5004	864	310	2/3
3	S349-0009	763	413	3/3	10	S349-9004	805	355	2/3
4	S349-1009	1375	399	1/3	11	S349-9306	1328	877	1/3
5	S349-1010	1375	399	1/3	12	ZQ2-581	350	120	2/3
6	S349-2004	899	399,5	2/3	13	ZQ3-503	350	120	1/3
7	S349-3004	834	378	2/3	14	ZQ3-504	350	120	1/3

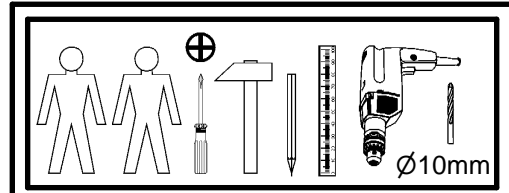
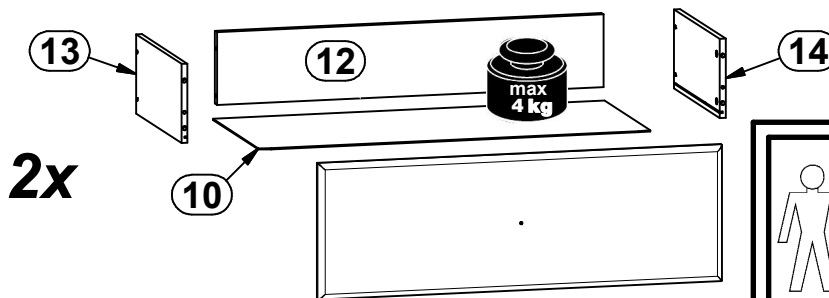
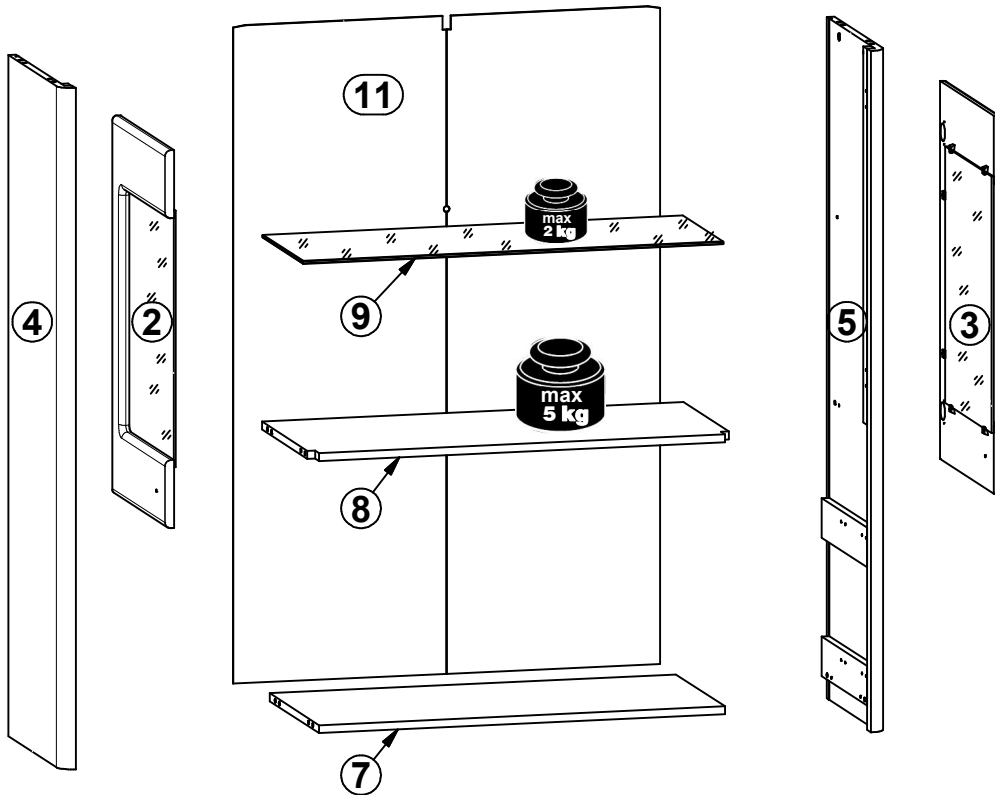
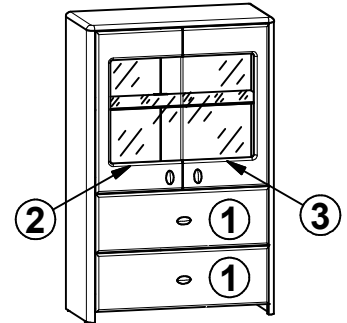

2x K16 a43	2x K16: 4x hamulec a101	2x b60	2x H2 b66	4x M4 c437	4x Ø5x17 mm d3	16x Ø6x13 mm e3	8x Ø5x30 mm e57	12x Ø8x30 mm f1
4x Ø6x30 mm f9	8x Ø6.5x40 mm f25	1x Ø10x50 mm f35	4x M4x28 mm j11	4x k1	20x l1	12x I2	1x 86x21x191.5 n14\2	1x o43\6
1x o43\8	1x Ø5x60 mm p17	2x Ø3.5x16 mm p25	2x Ø3.5x10 mm p35	18x Ø3.5x16 mm p38	8x Ø3.5x15 mm p51	12x Ø15x12 mm #16 r1	8x Ø12x10.5 mm #12 r15	20x 20x11 r42
2x 350 mm t35	2x 350 mm W117\L	2x 350 mm W117\P	4x Ø 20mm s68					

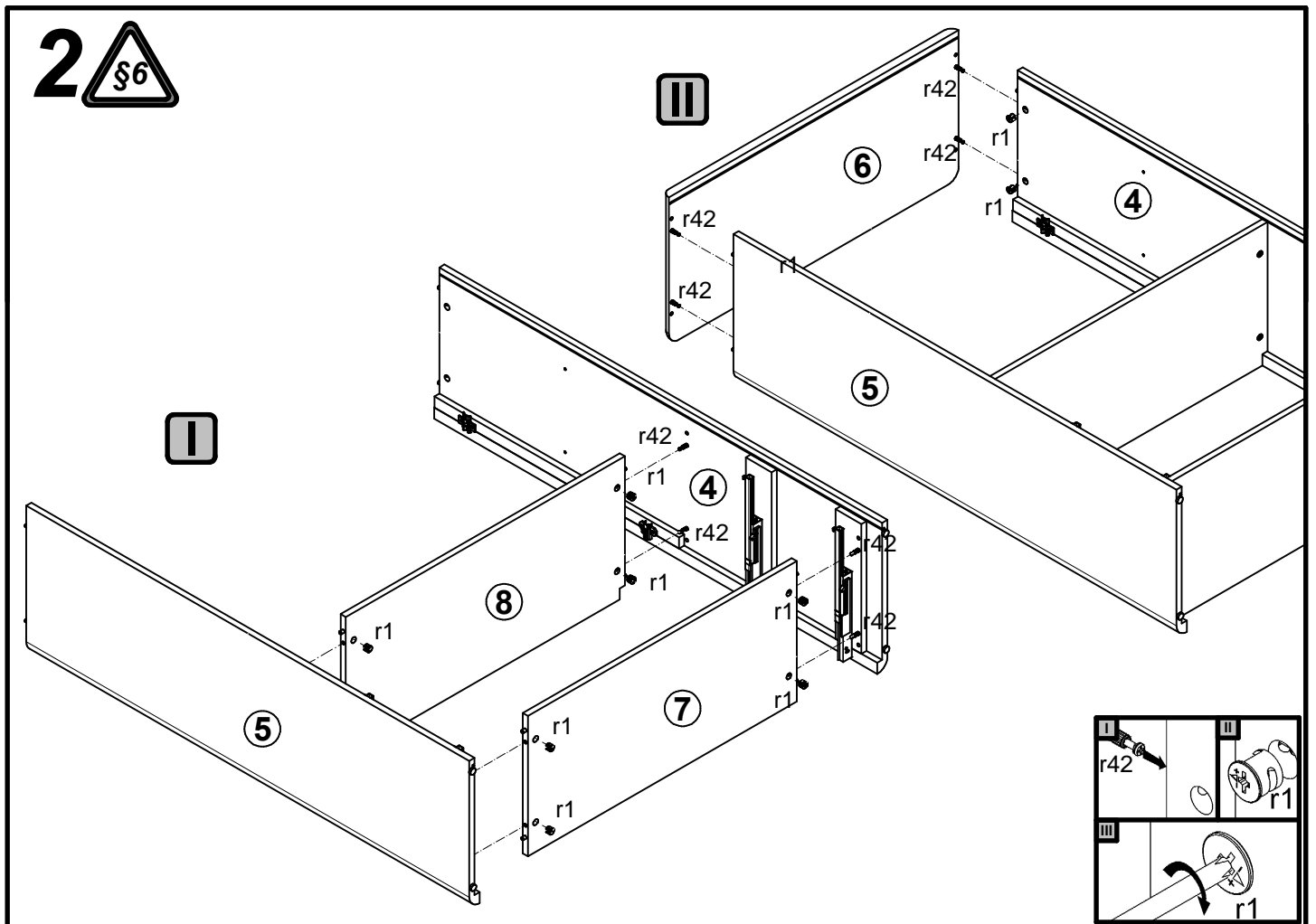
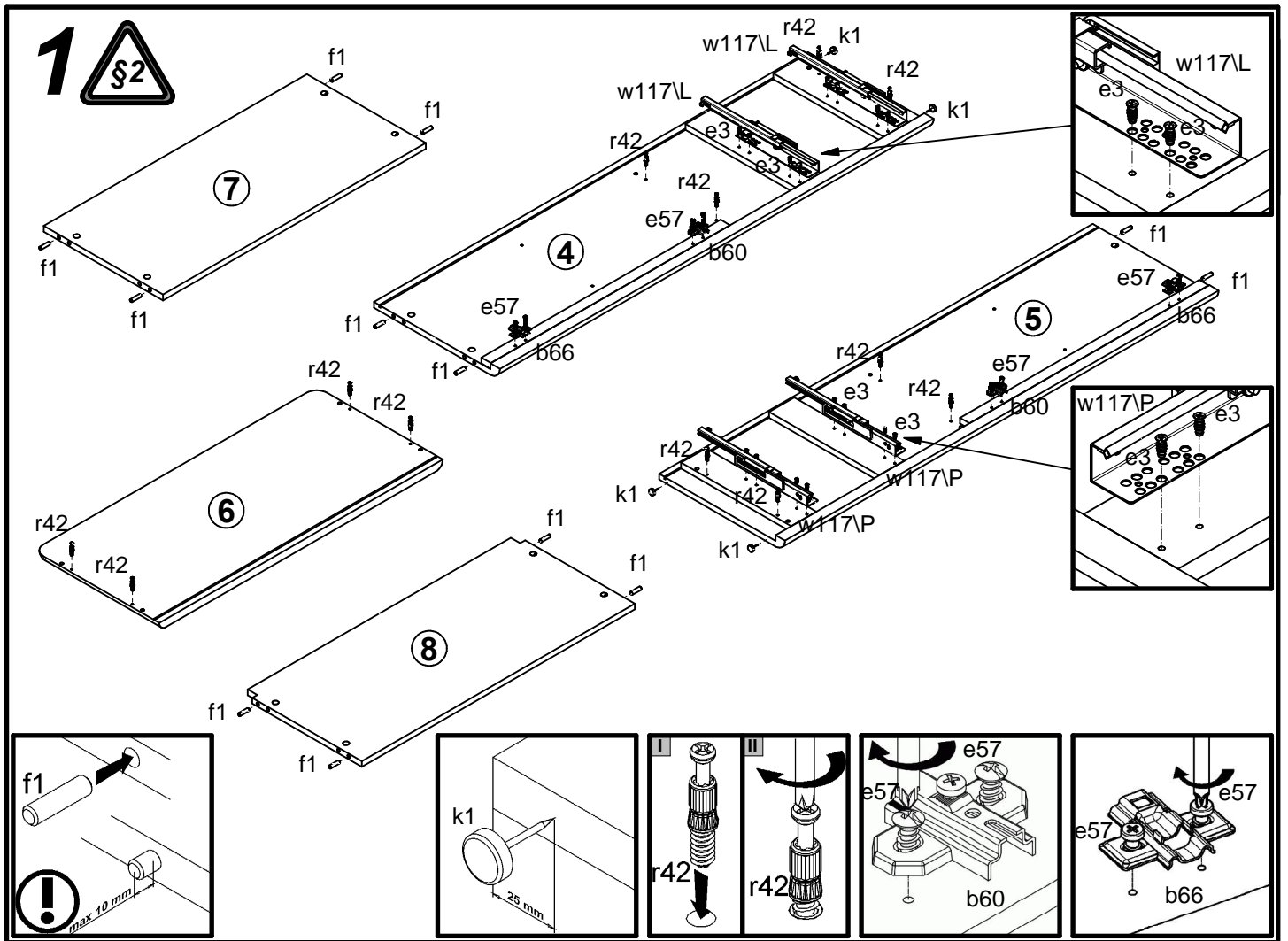

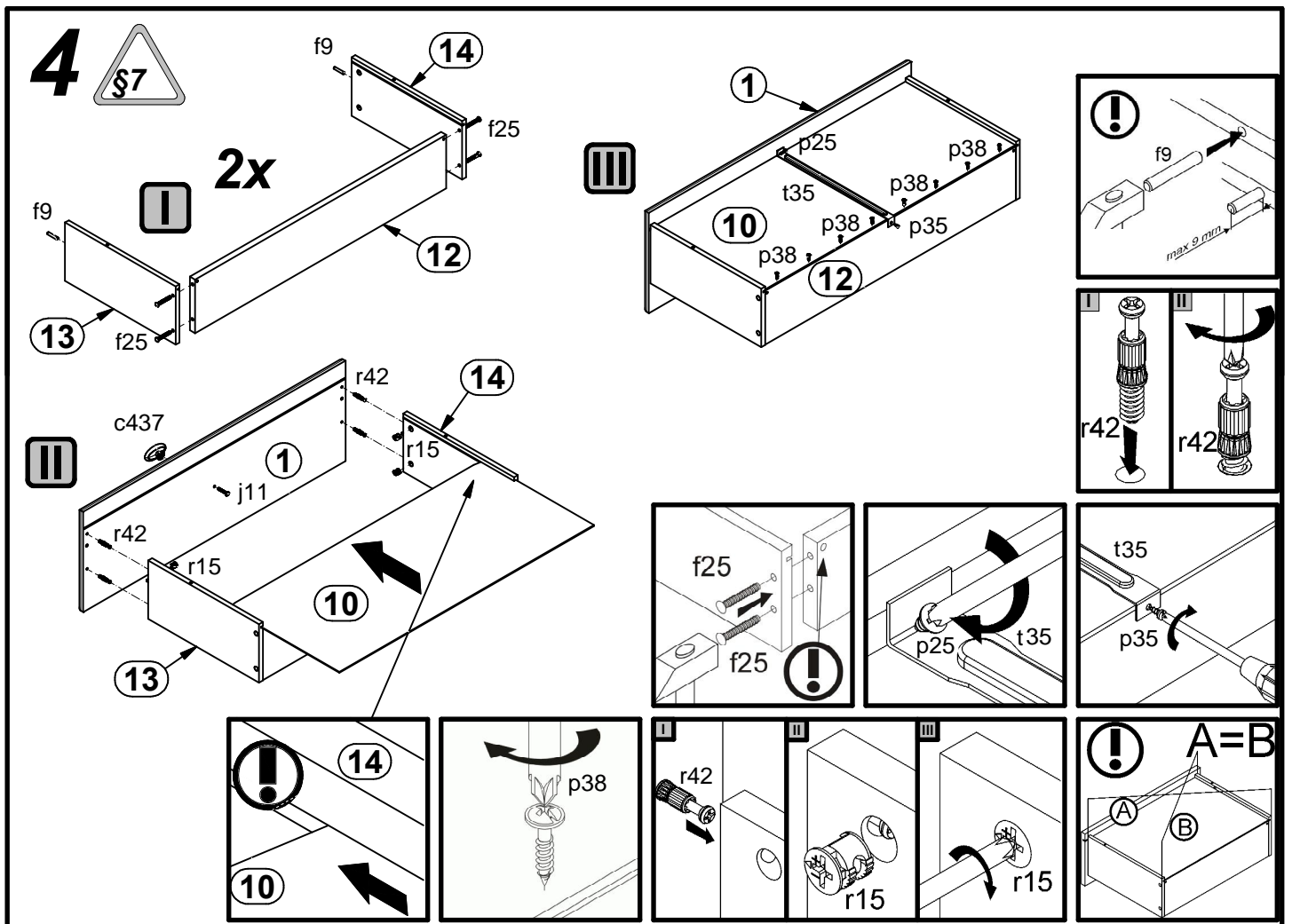
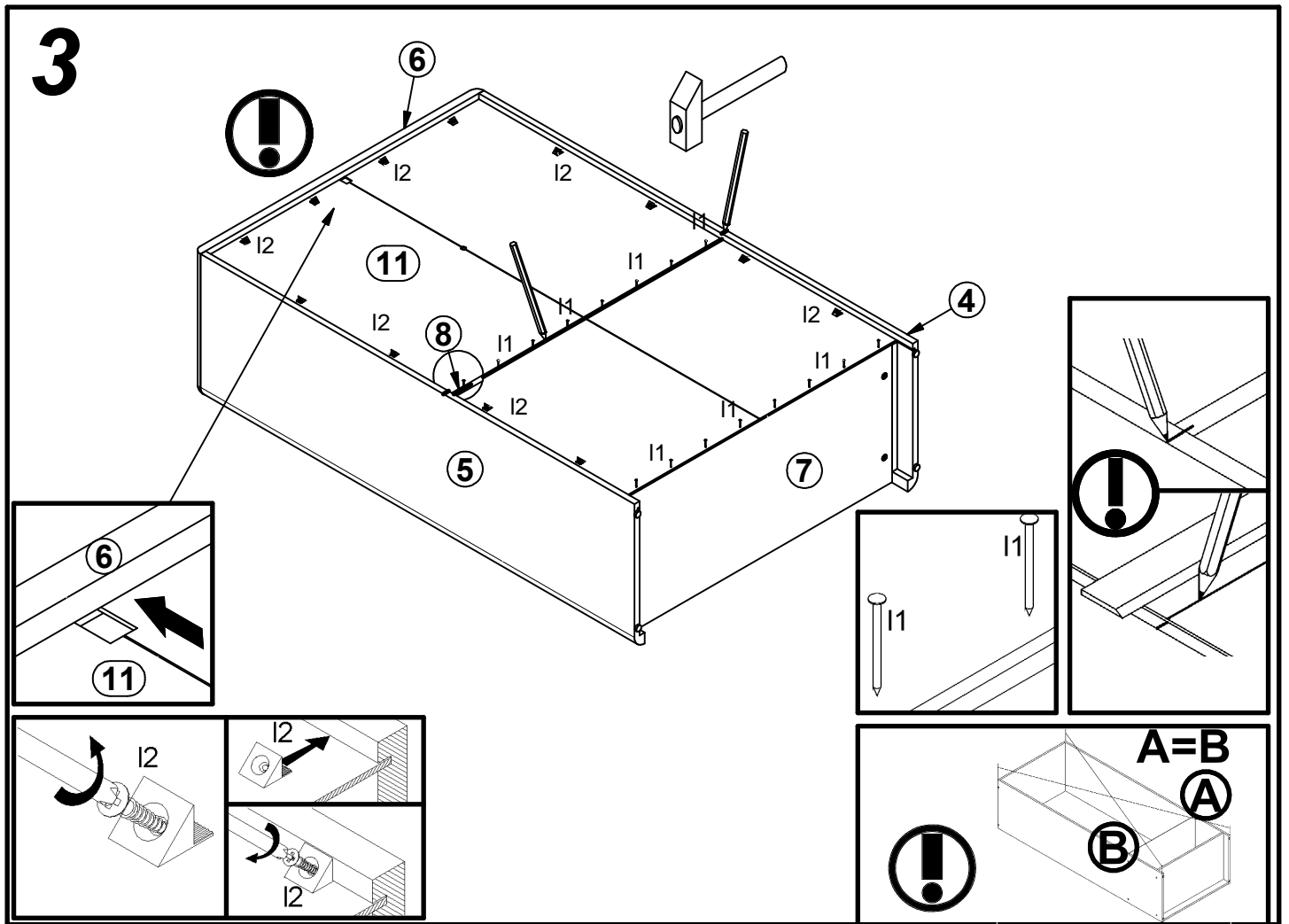

# 5



## I

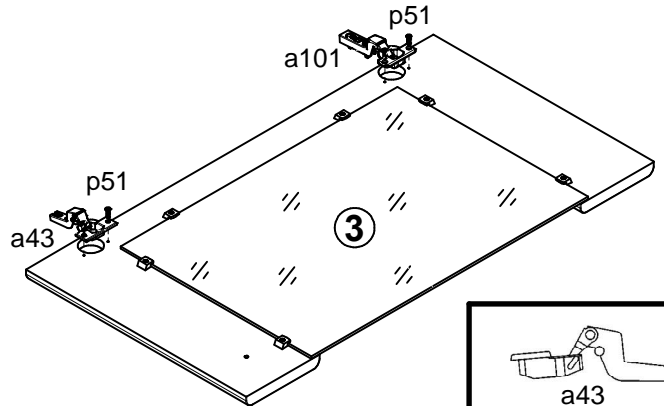
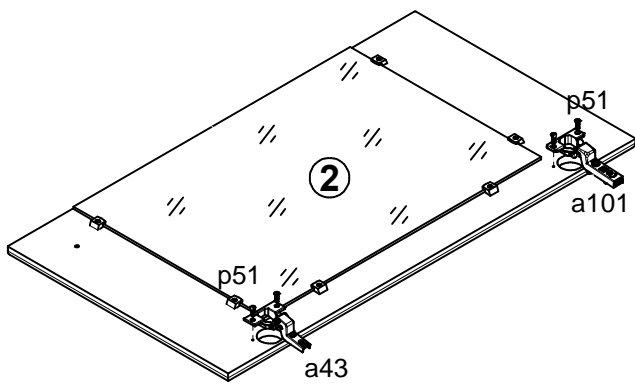

## III

f35 n14\2  
p17

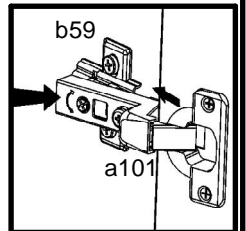
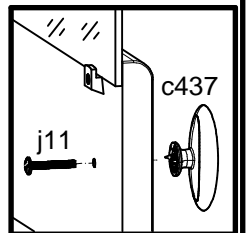
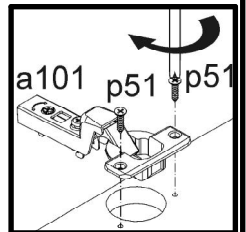
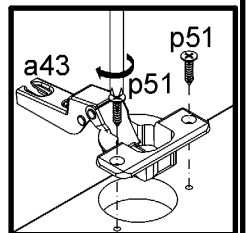
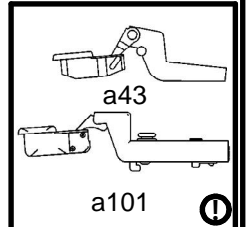
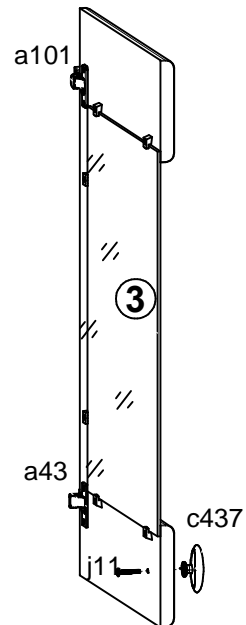
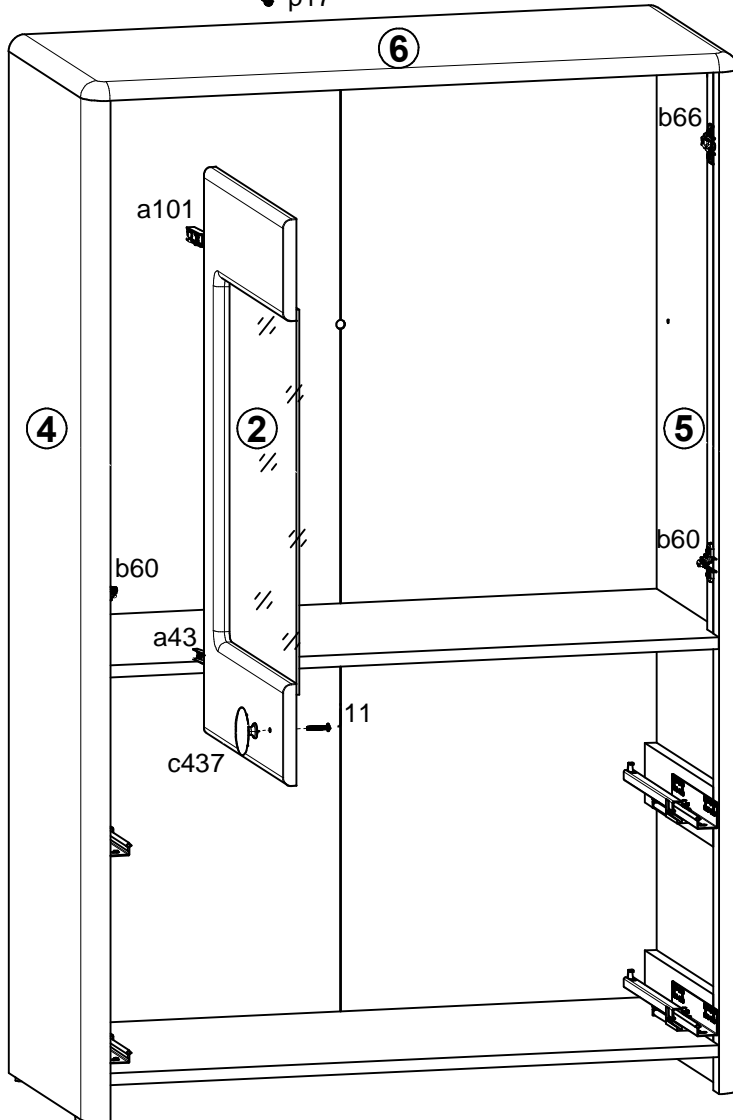

# §4

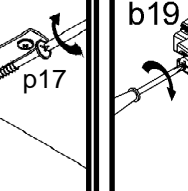
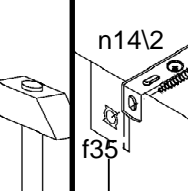
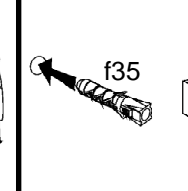
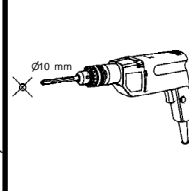
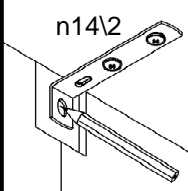
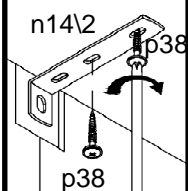

6 §11

I

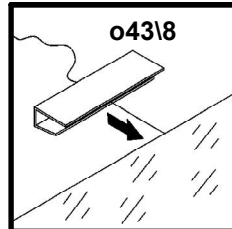
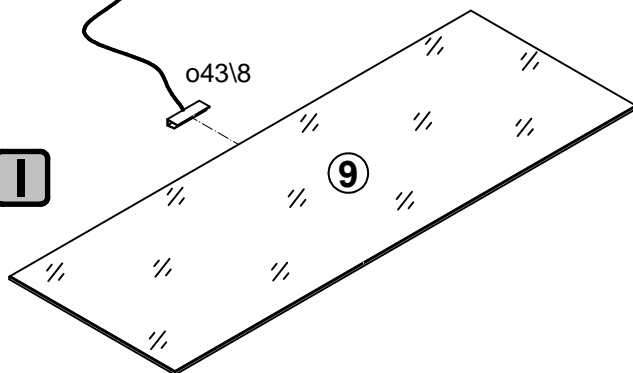

II

